

10G XFP DWDM 40KM SOXD-XX99-40

● Features :

- Supports 9.95Gb/s to 11.1Gb/s bit Rates
- Hot-Pluggable XFP Footprint
- Temperature-Stabilized DWDM Rated EML Transmitter
- Duplex LC Connector
- Built-in Digital Diagnostic Functions
- Operating Case Temperature:
- Standard: -40°C to 85°C

● Applications :

- 10GBASE-ER/EW 10G Ethernet
- 1200-SM-LL-L 10G Fiber Channel
- SONET OC-192 IR-2
- SDH STM S-64.2b
- SONET OC-192 IR-3
- SDH STM S-64.3b
- ITU-T G.709

● Absolute Maximum Ratings

Table 1- Absolute Maximum Ratings

Parameter	Symbol	Min.	Typical	Max.	Unit	Notes
Storage Temperature	Ts	-40	-	85	°C	
Supply Voltage	Vcc3	-0.5	-	4.0	V	
Operating Humidity	RH	-	-	+85	%	

● Recommended Operating Conditions

Table 2- Recommended operating Conditions

10G XFP DWDM 40KM SOXD-XX99-40

Parameter	Symbol	Min.	Typical	Max.	Unit	Notes
Operating Case Temperature	T _{op}	0	-	70	°C	
Power Supply Voltage	V _{CC5}	4.75	5.0	5.25	V	
	V _{CC3}	3.14	3.3	3.46	V	
Power Supply Current	I _{CC5}	-	-	370	mA	
	I _{CC3}	-	-	500	mA	
Power Dissipation	PD	-	-	3.5	W	
Data Rate	BR	9.95		11.3	Gbps	
Transmission Distance	TD	2		40000	m	

● Electrical Characteristics

Table 3- Electrical Characteristics

Transmitter						
Parameter	Symbol	Unit	Min.	Typ.	Max.	Notes
Differential Data Input swing	V _{in,p-p}	mVpp	120	-	820	
Input Differential impedance	Z _{in}	Ω	85	100	115	
Tx_Disable,P_Down/RST	V _{IL}	V	-0.3		0.8	
	V _{IH}	V	2.0	-	V _{CC} +0.3	
Receiver						
Differential Data Output	V _{out}	mVpp	340		850	
Output Differential impedance	Z _{in}	Ω	85	100	115	
Output Rise Time,20%-80%	T _r	Ps	24			
Output Fall Time,20%-80%	T _f	Ps	24			
Rx_Los,Mod_NR,Interrupt	V _{oL}	V	0		0.4	
	V _{oH}	V	V _{CC} -0.5		V _{CC} +0.3	

● Transmitter Performance :

Table 4- optical TX Characteristics

10G XFP DWDM 40KM
SOXD-XX99-40

Parameter		Symbol	Min.	Typical	Max.	Unit	Notes
Tx_Fault	Normal Operation	VOL	-0.3	-	0.4	V	
	Transmitter Fault	VOH	2.4	-	Vcc	V	
	Laser Disable	VIH	2.0	-	VCC+0.3	V	
Average Launch Optical Power		Pout	-1	-	+2	dBm	1
Extinction Ratio		ER	8.2	-	-	dB	2
Average Launch power of OFF TX		Poff	-	-	-30	dBm	1
Optical Wavelength		λ	1xx1-0.1	1xx1	1xx1+0.1	nm	
Dispersion penalty@9.95/10.7Gpbs		DP1	-	-	2	dB	2
Dispersion penalty@11.1/11.3Gpbs		DP2	-	-	3	dB	3
Side Mode Suppression Ratio		SMSR	30	-	-	dB	

● **Receiver Performance :**

Table 5- optical RX Characteristics

Parameter		Symbol	Min.	Typical	Max.	Unit	Notes
Receiver Sensitivity @9.95Gpbs/10.7Gpbs		PIN_SENS1	-	-	-16	dBm	2
Receiver Sensitivity @11.1Gpbs/11.3Gpbs		PIN_SENS2	-	-	-14	dBm	3
Overload		PIN_OL	-1	-		dBm	3
Optical Center Wavelength		λ_C	1270	-	1600	nm	
Los Assert		LOSA	-28	-	-	dBm	
Los De-assert		LOSD	-	-	-17	dBm	
Los hysteresis		LOSH	0.5	-		dB	
Rx_LOS	High		2.0		Vcc+0.3	V	

10G XFP DWDM 40KM
SOXD-XX99-40

	Low		0		0.8	V	
--	-----	--	---	--	-----	---	--

Note:

1. The optical power is launched into SMF.
2. Measured with a PRBS 231-1 test pattern @9.95Gbps.
3. Measured with a PRBS 231-1 test pattern , @11.1Gbps. BER≤10⁻¹².

● **Recommended Host Board Power Supply Circuit**

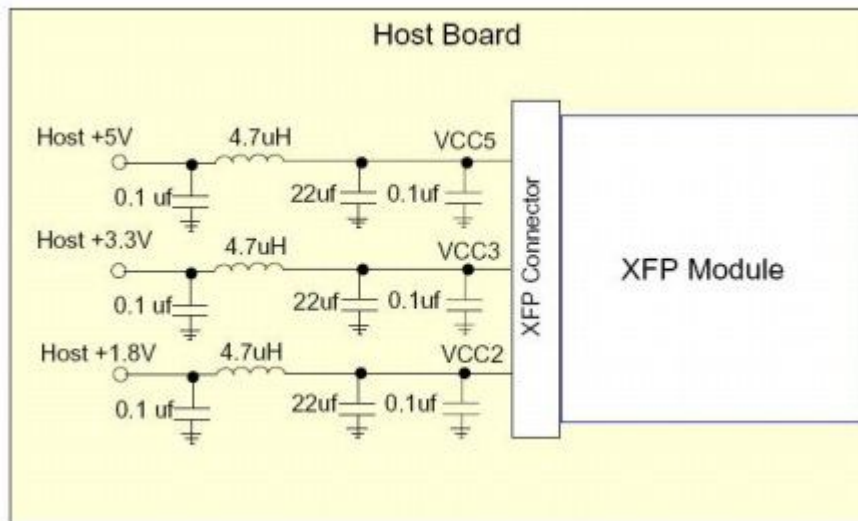

Figure 1,Recommended host board power supply circuit

10G XFP DWDM 40KM SOXD-XX99-40

- Recommended interface circuit

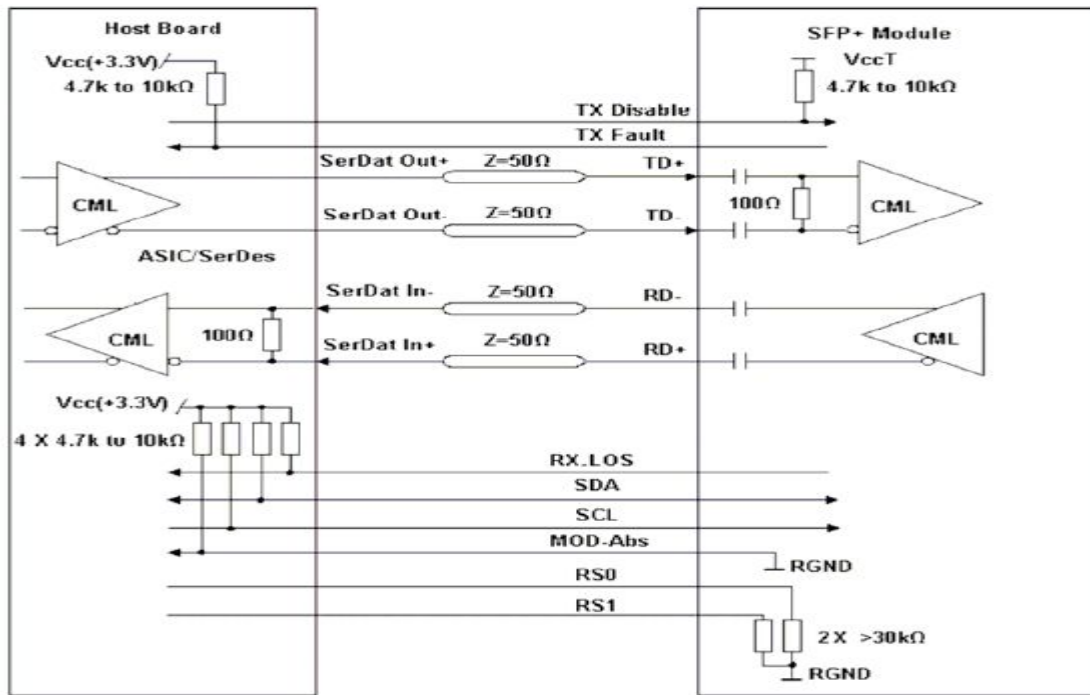

Figure 2, recommended interface circuit

10G XFP DWDM 40KM SOXD-XX99-40

● XFP Pins Definitions :

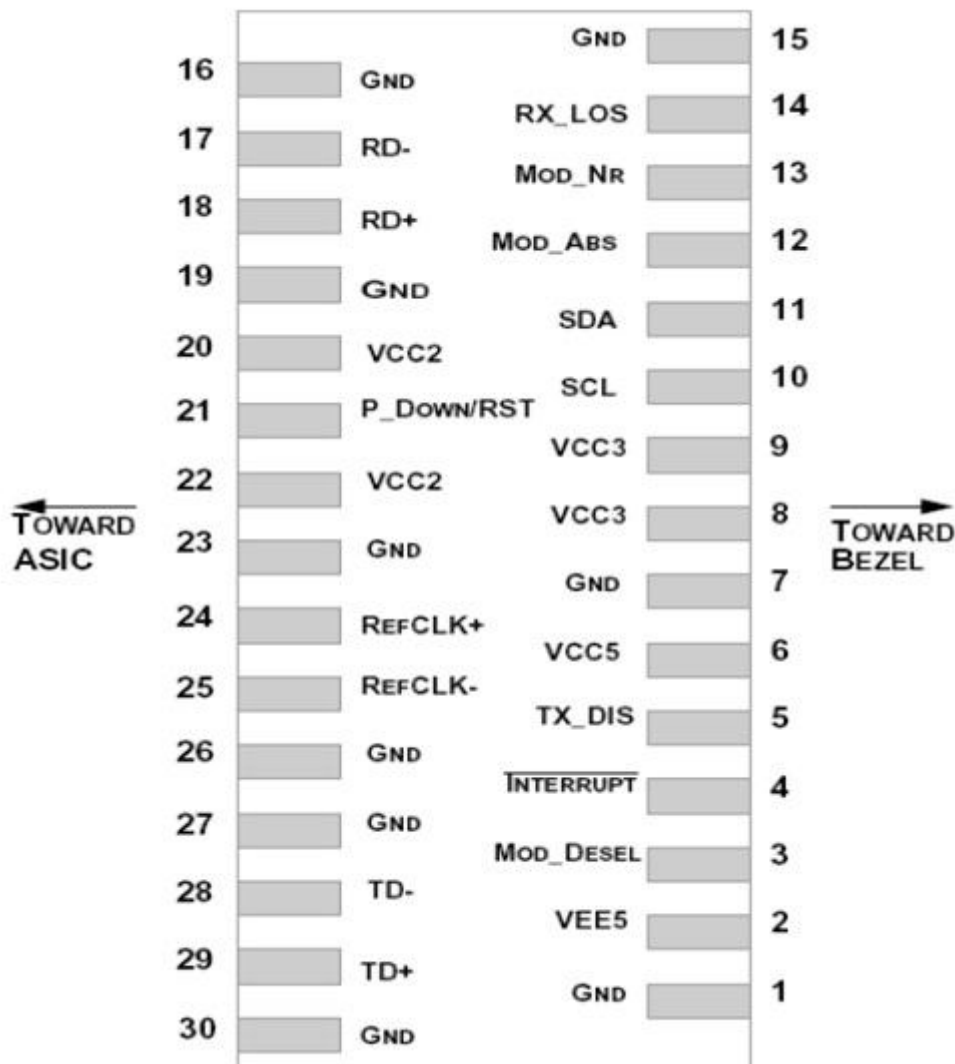

Figure 3,pins definitions

Table 6- Pin Definitions

Pin	Logic	Symbol	Name/Description	Note
1		GND	Module Ground	1
2		VEE5	Optional -5.2V Power Supply	
3	LVTTTL-I	MOD_DESEL	Module De-select; When held low allows the module to respond to 2-wire serial interface	
4	LVTTTL-O	INTb	Interrupt; Indicates presence of an important condition which can be read via	2

10G XFP DWDM 40KM SOXD-XX99-40

			the 2-wire serial interface	
5	LVTTL-I	TX_DIS	Transmitter Disable; Turns off transmitter laser output	
6		VCC5	+5V Power Supply	
7		GND	Module Ground	1
8		VCC3	+3.3V Power Supply	
9		VCC3	+3.3V Power Supply	
10	LVTTL-I/O	SCL	2-Wire Serial Interface Clock	2
11	LVTTL-I/O	SDA	2-Wire Serial Interface Data Line	2
12	LVTTL-O	MOD_Abs	Indicates Module is not present. Grounded in the Module	2
13	LVTTL-O	MOD_NR	Module Not Ready; Indicating Module Operational Fault	2
14	LVTTL-O	RX_LOS	Receiver Loss Of Signal Indicator	2
15		GND	Module Ground	1
16		GND	Module Ground	1
17	CML-O	RDN	Receiver Inverted Data Output	
18	CML-O	RDP	Receiver Non-Inverted Data Output	
19		GND	Module Ground	1
20		VCC2	+1.8V Power Supply	
21	LVTTL-I	P_DOWN/RST	Power down; When high, requires the module to limit power consumption to 1.5W or below. 2-Wire serial interface must be functional in the low power mode.	
			Reset; The falling edge initiates a complete reset of the module including the 2-wire serial interface, equivalent to a power cycle.	
22		V _{CC2}	+1.8V Power Supply	
23		GND	Module Ground	1
24	PECL-I	REFCLKP	Not used, internally terminated to 50ohm (100ohm diff).	3
25	PECL-I	REFCLKN	Not used, internally terminated to 50ohm (100ohm diff).	3
26		GND	Module Ground	1
27		GND	Module Ground	1
28	CML-I	TDN	Transmitter Inverted Data Input	
29	CML-I	TDP	Transmitter Non-Inverted Data Input	
30		GND	Module Ground	1

Note:

1. Module circuit ground is isolated from module chassis ground within the module.
2. Open collector; should be pulled up with 4.7k – 10k ohm on host board to a voltage between 3.15V and 3.6V.
3. A Reference Clock input is not required.

10G XFP DWDM 40KM
SOXD-XX99-40

Mechanical Dimension :

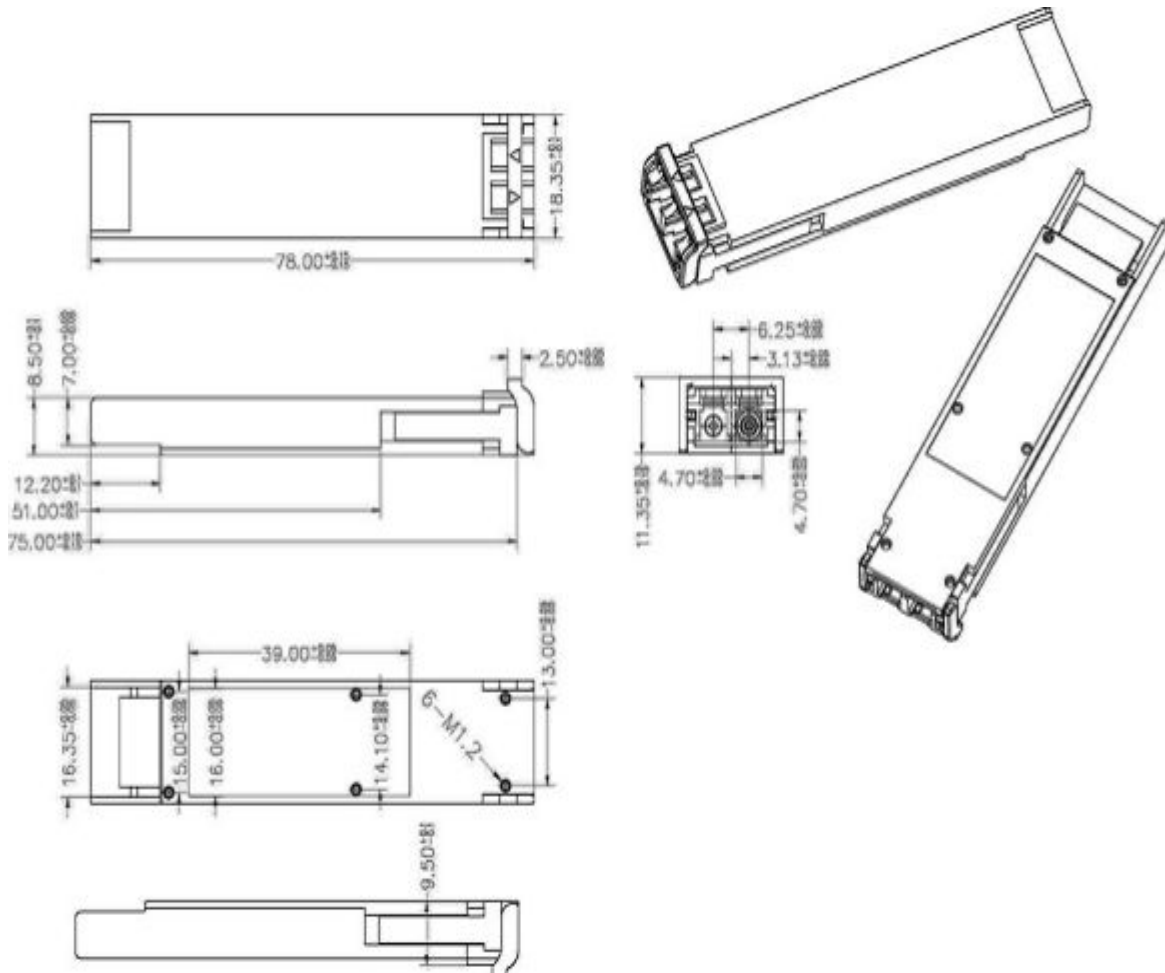

Figure 4,mechanical dimension

● **Order Information and Related Products :**

Table 7-order information

Part Number	Product Description
SOXD-XX99-40	XFP DWDM EML, 0℃~70℃, 40Km

Wavelength Guide (value)**

Table 7-wavelength guide

ITU channel (**)	Frequency (THz)	Wavelength (nm)	ITU Channel (**)	Frequency (THz)	Wavelength (nm)
17	191.7	1563.863	40	194.0	1545.322
18	191.8	1563.047	41	194.1	1544.526
19	191.9	1562.233	42	194.2	1543.730

10G XFP DWDM 40KM
SOXD-XX99-40

20	192.0	1561.419	43	194.3	1542.936
21	192.1	1560.606	44	194.4	1542.142
22	192.2	1559.794	45	194.5	1541.349
23	192.3	1558.983	46	194.6	1540.557
24	192.4	1558.173	47	194.7	1539.766
25	192.5	1557.363	48	194.8	1538.976
26	192.6	1556.555	49	194.9	1538.186
27	192.7	1555.747	50	195.0	1537.397
28	192.8	1554.940	51	195.1	1536.609
29	192.9	1554.134	52	195.2	1535.822
30	193.0	1553.329	53	195.3	1535.036
31	193.1	1552.524	54	195.4	1534.250
32	193.2	1551.721	55	195.5	1533.465
33	193.3	1550.918	56	195.6	1532.681
34	193.4	1550.116	57	195.7	1531.898
35	193.5	1549.315	58	195.8	1531.116
36	193.6	1548.515	59	195.9	1530.334
37	193.7	1547.715	60	196.0	1529.553
38	193.8	1546.917	61	196.1	1528.773
39	193.9	1546.119			

● **Notice**

SINOVO reserves the right to make changes to or discontinue any optical link product or service identified in this publication, without notice, in order to improve design and/or performance. Applications that are described herein for any of the optical link products are for illustrative purposes only. SINOVO makes no representation or warranty that such applications will be suitable for the specified use without further testing or modification.

● **Contact**

Shenzhen Sinovo Telecom Co.,Ltd
 Tel:+86(0)0755-32959919 Fax:+86(0)755 32959918
 Email: sales@sinovocorp.com
 Web:www.sinovocorp.com
 Factory ADD:5/F Chuang Park,Taoyuan Street Baoan District,Shenzhen,China
 Head Quarter:11/F, Taibang Technology Building,Gaoxin South 4th,Science and Technology Park South,Nanshan,Shenzhen,China 518040