

## 10G XFP CWDM 80KM SOXC-xx99-80

### ● **Features :**

- Supports 9.95Gb/s to 11.1Gb/s Bit Rates
- Hot-Pluggable XFP Footprint
- Compliant with XFP MSA
- CWDM EML Transmitter  
from 1470nm to 1610nm, with Step 20nm
- Very Low TEC Power Consumption
- Duplex LC Connector
- Power Dissipation < 3.5W
- Case Operation Temperature Range  
0°C to 70°C
- 2-Wire Interface for Integrated Digital  
Diagnostic Monitoring

### ● **Applications :**

- OC-192, STM-64
- 10GBASE-ZR/ZW 10G Ethernet
- 1200-SM-LL-L 10G Fiber Channel
- 10GE over G.709 at 11.09Gbps
- OC192 over FEC at 10.709Gbps

### ● **Absolute Maximum Ratings**

**Table 1- Absolute Maximum Ratings**

Parameter	Symbol	Min.	Typical	Max.	Unit	Notes
Storage Temperature	Ts	-40	-	85	°C	
Supply Voltage	Vcc5	-0.5	-	4.0	V	
Operating Humidity	RH	-	-	+85	%	

## 10G XFP CWDM 80KM SOXC-xx99-80

### ● Recommended Operating Conditions

**Table 2- Recommended operating Conditions**

Parameter	Symbol	Min.	Typical	Max.	Unit	Notes
Operating Case Temperature	Top	0	-	70	°C	
Power Supply Voltage	Vcc5	4.75	5.0	5.25	V	
	VCC3	3.14	3.3	3.46	V	
Power Supply Current	ICC5	-	-	370	mA	
	ICC3	-	-	500	mA	
Power Dissipation	PD	-	-	3.5	W	
Data Rate	BR	9.95		11.3	Gbps	
Transmission Distance	TD		80		km	

### ● Electrical Characteristics

**Table 3- Electrical Characteristics**

Transmitter						
Parameter	Symbol	Unit	Min	Typ	Max	Notes
Differential Data Input Amplitude	Vin,p-p	mVpp	120	-	820	
Input Differential impedance	Zin	Ω	85	100	115	
Tx_Disable,P_Down/RST	VIL	V	-0.3		0.8	
	VIH	V	2.0	-	Vcc+0.3	
Receiver						
Differential Data Output Amplitude	Vout,p-p	mVpp	340		850	
Output Differential impedance	Zin	Ω	80	100	120	
Output Rise Time,20%-80%	Tr	Ps	28			
Output Fall Time,20%-80%	Tf	Ps	28			
Rx_Los,Mod_NR,Interrupt	VoL	V	0		0.4	
	VoH	V	Vcc-0.5		Vcc+0.3	

## 10G XFP CWDM 80KM SOXC-xx99-80

### ● Transmitter Performance :

**Table 4- optical TX Characteristics**

Parameter		Symbol	Min.	Typical	Max.	Unit	Notes
Tx_Fault	Normal Operation	VOL	-0.3	-	0.4	V	
	Transmitter Fault	VOH	2.4	-	Vcc	V	
	Laser Disable	VIH	2.0	-	VCC+0.3	V	
Average Launch Optical Power		Pout	0	-	+4	dBm	1
Extinction Ratio		ER	9	-	-	dB	2
Average Launch power of OFF TX		Poff	-	-	-30	dBm	1
Optical Wavelength		$\lambda$	$\lambda_c-6.5$	$\lambda_c$	$\lambda_c+6.5$	nm	
Dispersion penalty@9.95/10.7Gpbs		DP1	-	-	2	dB	2
Dispersion penalty@11.1/11.3Gpbs		DP2	-	-	3	dB	3
Side Mode Suppression Ratio		SMSR	30	-	-	dB	

### ● Receiver Performance :

**Table 5- optical RX Characteristics**

Parameter	Symbol	Min.	Typical	Max.	Unit	Notes
Receiver Sensitivity @9.95Gpbs/10.7Gpbs	PIN_SENS1	-	-	-24	dBm	2
Receiver Sensitivity @11.1Gpbs/11.3Gpbs	PIN_SENS2	-	-	-23	dBm	3
Overload	PIN_OL	-7.0	-		dBm	3
Optical Center Wavelength	$\lambda_C$	1270	-	1600	nm	
Los Assert	LOSA	-38	-	-	dBm	
Los De-assert	LOSD	-	-	-26	dBm	

## 10G XFP CWDM 80KM SOXC-xx99-80

Los hysteresis		LOSH	0.5	-		dB	
Rx_LOS	High		2.0		V <sub>cc</sub> +0.3	V	
	Low		0		0.8	V	

**Note:**

1. The optical power is launched into SMF.
2. Measured with a PRBS 231-1 test pattern @9.95Gbps.
3. Measured with a PRBS 231-1 test pattern , @11.1Gbps. BER≤10<sup>-12</sup>.

### ● Recommended Host Board Power Supply Circuit

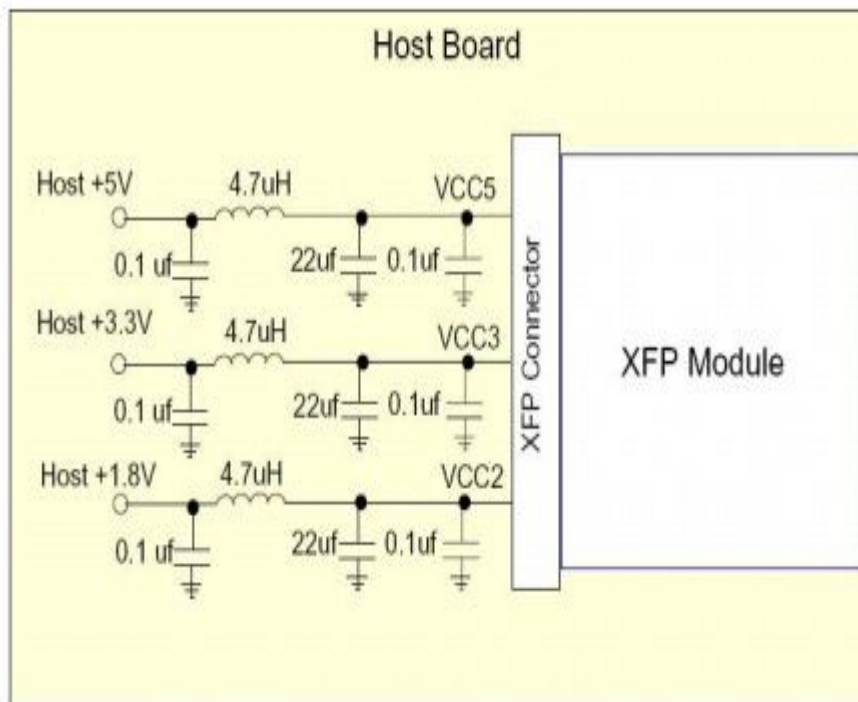

Figure 1, recommended host board power supply circuit

# 10G XFP CWDM 80KM SOXC-xx99-80

- Recommended interface circuit

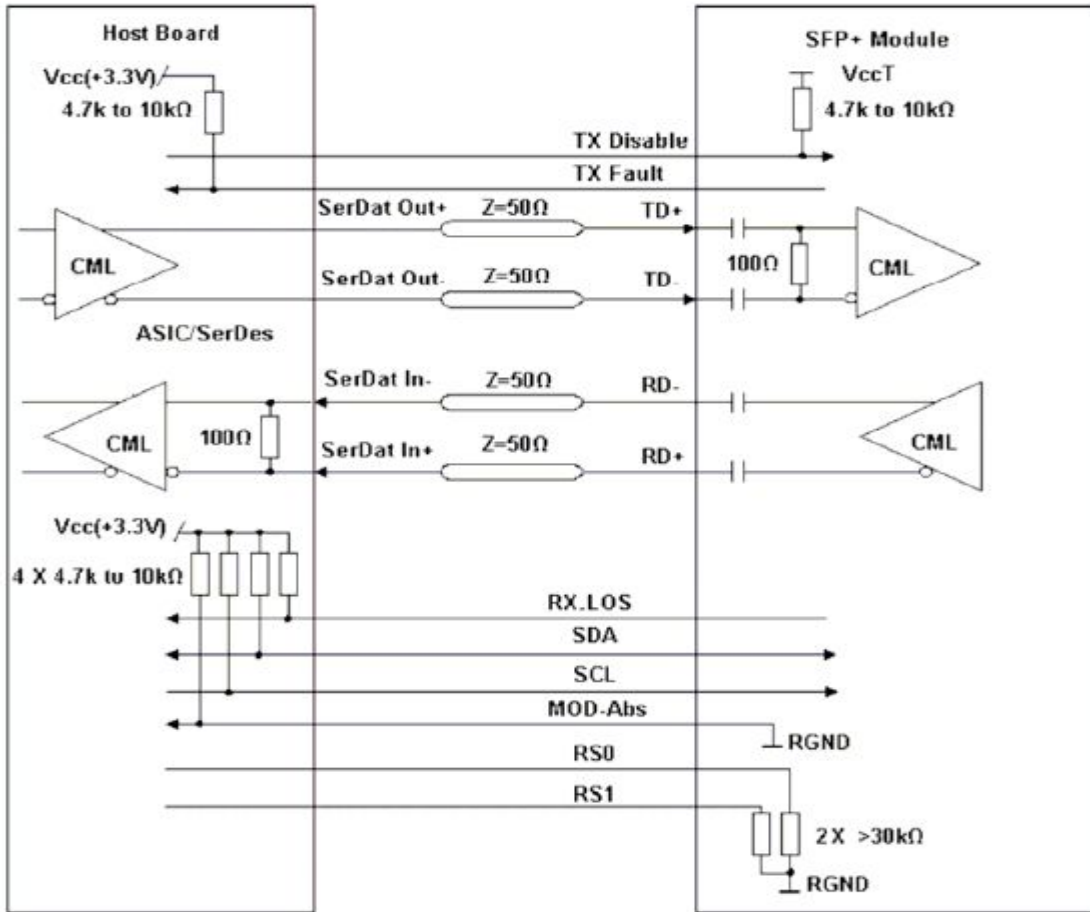

Figure 2, recommended interface circuit

## 10G XFP CWDM 80KM SOXC-xx99-80

### ● XFP Pins Definitions :

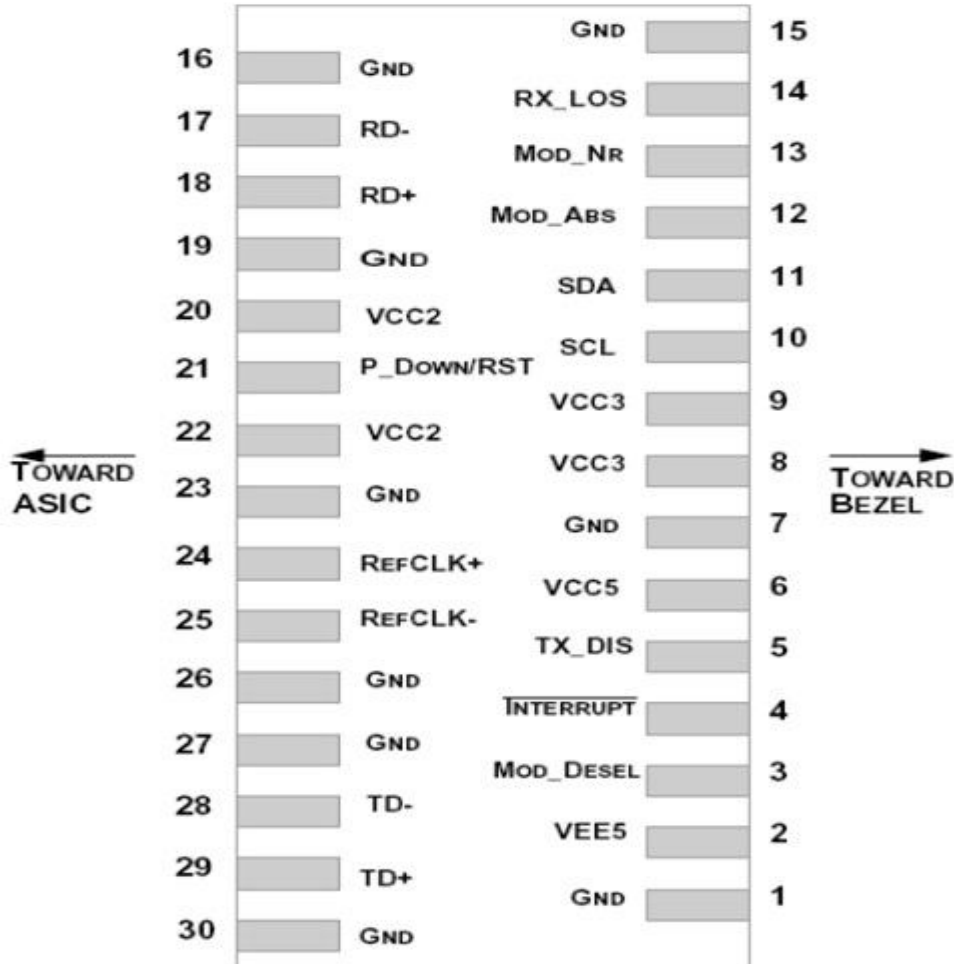

Figure 3,pins definitions

**Table 6- Pin Definitions**

Pin	Logic	Symbol	Name/Description	Note
1		GND	Module Ground	1
2		VEE5	Optional -5.2V Power Supply	
3	LVTTL-I	MOD_DESEL	Module De-select; When held low allows the module to respond to 2-wire serial interface	
4	LVTTL-O	INTb	Interrupt; Indicates presence of an important condition which can be read via the 2-wire serial interface	2

## 10G XFP CWDM 80KM SOXC-xx99-80

5	LVTTL-I	TX_DIS	Transmitter Disable; Turns off transmitter laser output	
6		VCC5	+5V Power Supply	
7		GND	Module Ground	1
8		VCC3	+3.3V Power Supply	
9		VCC3	+3.3V Power Supply	
10	LVTTL-I/O	SCL	2-Wire Serial Interface Clock	2
11	LVTTL-I/O	SDA	2-Wire Serial Interface Data Line	2
12	LVTTL-O	MOD_Abs	Indicates Module is not present. Grounded in the Module	2
13	LVTTL-O	MOD_NR	Module Not Ready; Indicating Module Operational Fault	2
14	LVTTL-O	RX_LOS	Receiver Loss Of Signal Indicator	2
15		GND	Module Ground	1
16		GND	Module Ground	1
17	CML-O	RDN	Receiver Inverted Data Output	
18	CML-O	RDP	Receiver Non-Inverted Data Output	
19		GND	Module Ground	1
20		VCC2	+1.8V Power Supply	
21	LVTTL-I	P_DOWN/RST	Power down; When high, requires the module to limit power consumption to 1.5W or below. 2-Wire serial interface must be functional in the low power mode.	
			Reset; The falling edge initiates a complete reset of the module including the 2-wire serial interface, equivalent to a power cycle.	

**10G XFP CWDM 80KM  
SOXC-xx99-80**

22		VCC2	+1.8V Power Supply	
23		GND	Module Ground	1
24	PECL-I	REFCLKP	Not used, internally terminated to 50ohm (100ohm diff).	3
25	PECL-I	REFCLKN	Not used, internally terminated to 50ohm (100ohm diff).	3
26		GND	Module Ground	1
27		GND	Module Ground	1
28	CML-I	TDN	Transmitter Inverted Data Input	
29	CML-I	TDP	Transmitter Non-Inverted Data Input	
30		GND	Module Ground	1

**Note:**

1. Module circuit ground is isolated from module chassis ground within the module.
2. Open collector; should be pulled up with 4.7k – 10k ohm on host board to a voltage between 3.15V and 3.6V.
3. A Reference Clock input is not required.



## 10G XFP CWDM 80KM SOXC-xx99-80

### ● Mechanical Dimension :

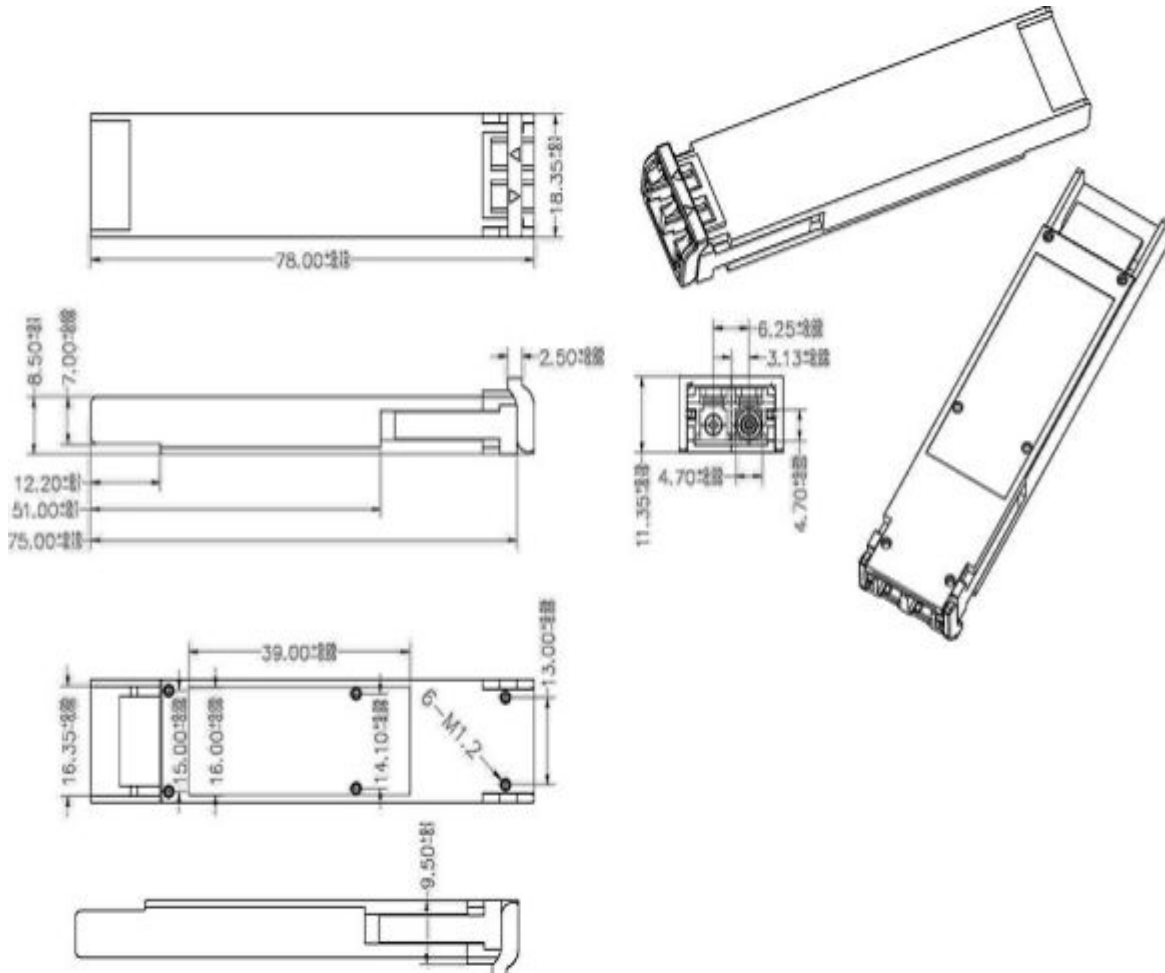

Figure 4,mechanical dimension

### ● Order Information and Related Products :

Table 7-order information

Part Number	Product Description
SOXC-XX99-80	XFP CWDM EML, 0°C~70°C, 80Km

### Wavelength Guide (\*\* value)

Table 7-wavelength guide

Band	Nomenclature“xx”		Wavelength(nm)		
	duplet	BiDI	Min.	Typ.	Max.
O-band Original	27	A	1264	1270	1277.5
	29	B	1294	1290	1297.5

**10G XFP CWDM 80KM**  
**SOXC-xx99-80**

	31	C	1304	1310	1317.5
	33	D	1324	1330	1337.5
	35	E	1344	1350	1357.5
E-band Extended	37	F	1364	1370	1377.5
	39	G	1384	1390	1397.5
	41	H	1404	1410	1417.5
	43	I	1324	1430	1437.5
	45	J	1444	1450	1457.5
S-band Short Wavelength	47	K	1464	1470	1477.5
	49	L	1484	1490	1497.5
	51	M	1504	1510	1517.5
	53	N	1524	1530	1537.5
C-band Conventional	55	O	1544	1550	1557.5
L-band Long Wavelength	57	P	1564	1570	1577.5
	59	Q	1584	1590	1597.5
	61	R	1604	1610	1617.5

- Notice

SINOVO reserves the right to make changes to or discontinue any optical link product or service identified in this publication, without notice, in order to improve design and/or performance. Applications that are described herein for any of the optical link products are for illustrative purposes only. SINOVO makes no representation or warranty that such applications will be suitable for the specified use without further testing or modification.

- Contact

Shenzhen Sinovo Telecom Co.,Ltd

Tel:+86(0)0755-32959919 Fax:+86(0)755 32959918

Email: sales@sinovocorp.com

Web:www.sinovocorp.com

Factory ADD:5/F Chuang Park,Taoyuan Street Baoan District,Shenzhen,China

Head Quarter:11/F, Taibang Technology Building,Gaoxin South 4<sup>th</sup>,Science and Technology Park South,Nanshan,Shenzhen,China 518040