

Features :

- Support 10GBASE-LR/10GBASE-LW/10G Fiber Channel application
- Compliant to SFP+ Electrical MSA SFF-8431
- Compliant to SFP+ Mechanical MSA SFF-8432
- Multi rate of up to 11.3Gbps
- Transmission distance up to 10km (SMF)
- +3.3V single power supply
- Low power consumption
- Operating case temp : -5~+85°C
- RoHS 6/6 compliant

Absolute Maximum Ratings

Table 1- Absolute Maximum Ratings

Parameter	Symbol	Min.	Typical	Max.	Unit	Notes
Supply Voltage	V _{CC3}	-0.5	-	+3.6	V	
Storage Temperature	T _s	-5	-	+85	°C	
Operating Humidity	RH	+5	-	+95	%	

Recommended Operating Conditions

Table 2- Recommended operating Conditions

Parameter	Symbol	Min.	Typical	Max.	Unit	Notes
Operating Case Temperature	T _C	0	-	+70	°C	
Power Supply Voltage	V _{CC}	3.14	3.3	3.47	V	
Power Supply Current	I _{CC}	-	-	300	mA	
Power Dissipation	P _d	-	-	1.0	W	
Bit Rate	BR	-	10.3125	-	Gbps	

Electrical Characteristics

Table 3- Electrical Characteristics

Parameter	Symbol	Min.	Typ.	Max.	Units	Notes
Transmitter						
Differential Data Input Swing	$V_{in,P-P}$	120	-	850	mV _{PP}	
Input Differential Impedance	Z_{IN}	80	100	120	Ω	
Tx_Fault	Normal Operation	V_{OL}	0	-	0.8	V
	Transmitter Fault	V_{OH}	2.0	-	V_{CC}	V
Tx_Disable	Normal Operation	V_{IL}	0	-	0.8	V
	Laser Disable	V_{IH}	2.0	-	$V_{CC}+0.3$	V
Receiver						
Differential Date Output	V_{out}	100	-	800	mV	
Output Differential Impedance	Z_D	80	100	120	Ω	
Output Rise Time(20-80%)	T_R	24	-	-	ps	
Output Fall Time (20-80%)	T_F	24	-	-	ps	
Rx_LOS	Normal Operation	V_{OL}	0	-	0.8	V
	Lose Signal	V_{oH}	2.0	-	V_{CC}	V

Optical Characteristics

Table 4-Optical Characteristics

Parameter	Symbol	Unit	Min	Typ	Max	Notes
Optical transmitter Characteristics						
Bit Rate	BR	Gbps	9.953	10.3125	11.3	
Center Wavelength Range	λ_c	nm	1290	1310	1330	
Average Launch power Tx_off	Poff	dBm	-	-	-45	
Launch Optical Power	P_0	dBm	-7.5	-	0	1
Extinction Ratio	ER	dB	3.8	-	-	
Jitter P-P	JP	ps	-	-	27	

SFP+ 10G Transceiver SOSP-3199-02

Jitter RMS	JR	ps	-	-	5	
Optical Rise/Fall time	Tr/tf	ps	-	-	100	
Eye Diagram	Compliant With IEEE 802.3-2005					
Optical receiver Characteristics						
Bit Rate	BR	Gbps	9.953	10.3125	11.3	
Receiver Sensitivity	RS	dBm	-	-	-14.7	2
Overload Input Optical Power	P _{IN}	dBm	0	-	-	2
Center Wavelength Range	λ _c	nm	1290	1310	1330	
LOS	LOS _D	dBm	-	-	-15.5	
	LOS _A		-24.5	-	-	
LOS Hysteresis		dB	0.5	-	-	

Note:

1. Coupled into 9/125 SMF.
2. Measured with PRBS 2³¹-1 test pattern @10.3125Gbps.BER=10E-12

Recommended Interface Circuit

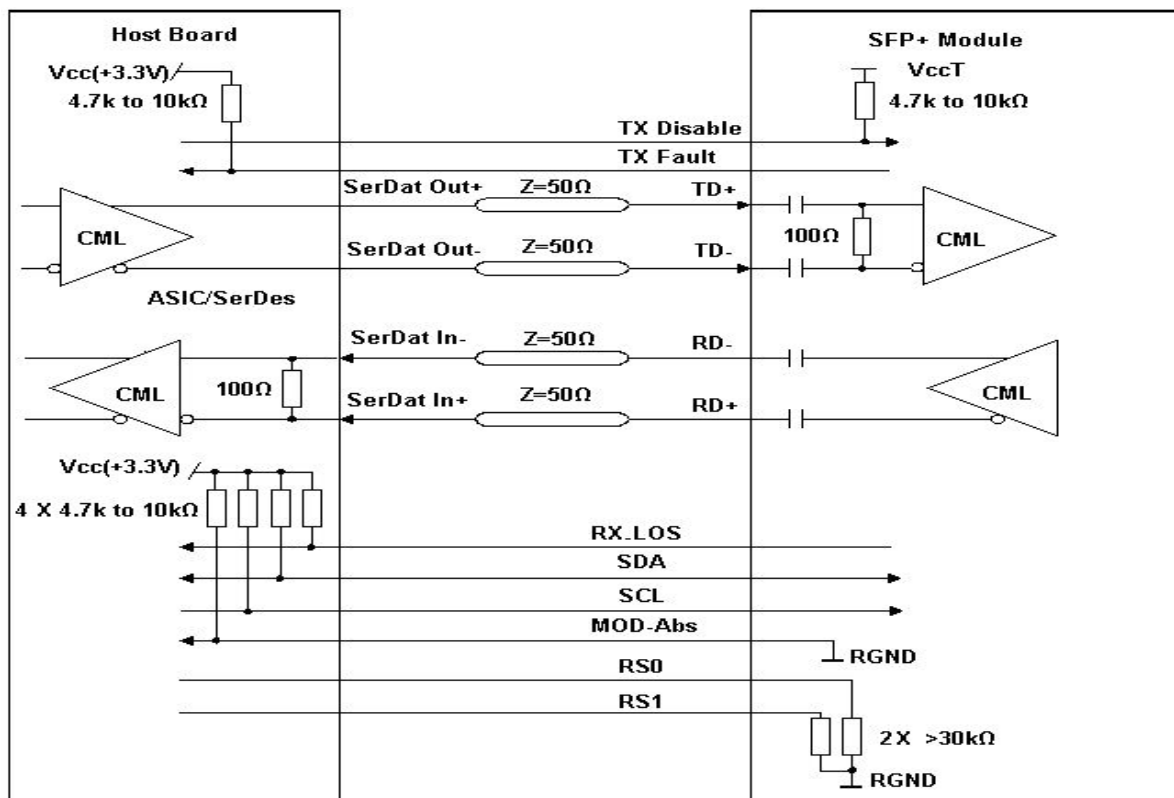

Figure 1, Recommended Interface Circuit

Recommended Host Board Power Supply Circuit

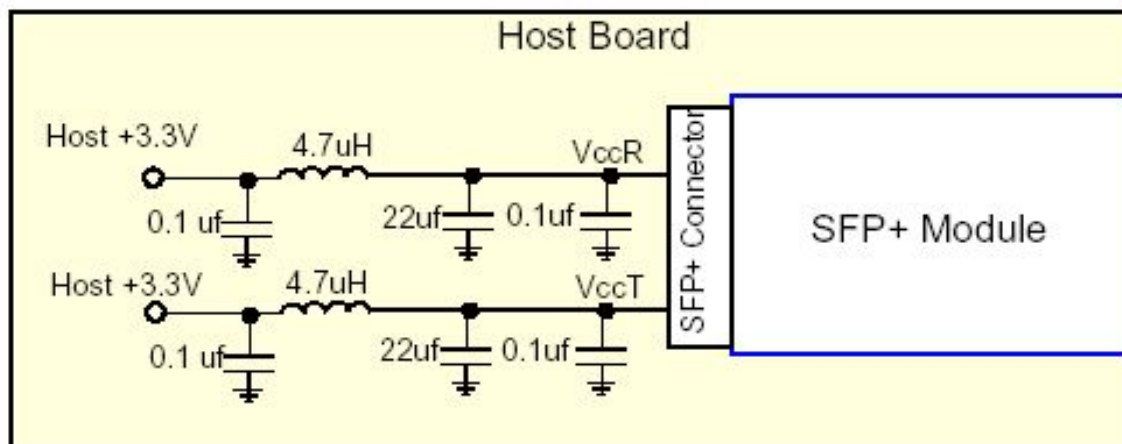

Figure 2, Recommended Host Board Power Supply Circuit

Pin arrangement

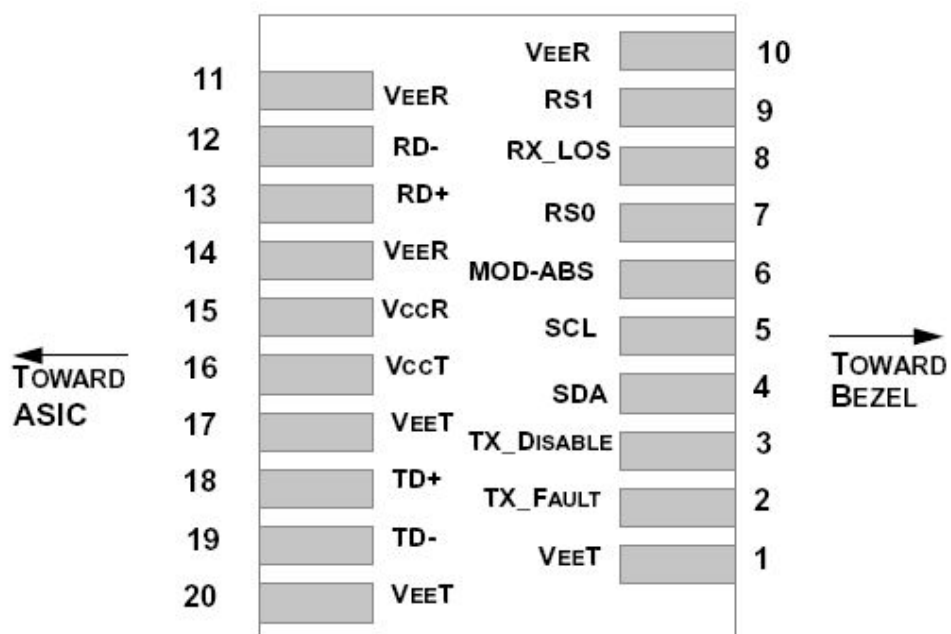

Figure 3, Pin View

SFP+ 10G Transceiver SOSP-3199-02

Table 5-Pin Function Definitions

Pin	Symbol	Name/Description	Notes
1	VEET	Module Transmitter Ground	1
2	TX_FAULT	Module Transmitter Fault	2
3	TX_DISABLE	Transmitter Disable; Turns off transmitter laser output	3
4	SDA	2-Wire Serial Interface Data Line (MOD-DEF2)	
5	SCL	2-Wire Serial Interface Clock (MOD-DEF1)	
6	MOD_ABS	Module Absent, connected to V _{EE} T or V _{EE} R in the	2
7	RS0	Rate Select 0, optionally controls SFP+ module receiver as the following when HIGH input Bit Rate>4.25 Gbps	
8	RX_LOS	Receiver Loss of Signal Indication (in FC designated as RX_LOS, in SONET designated as LOS,	2
9	RS1	Rate Select 1, optionally controls SFP+ module transmitter as the following when HIGH input Bit Rate>4.25 Gbps and when LOW input Bit Rate ≤4.25 Gbps.	
10	V _{EE} R	Module Receiver Ground	1
11	V _{EE} R	Module Receiver Ground	1
12	RD-	Receiver Inverted Data Output	
13	RD+	Receiver Non-Inverted Data Output	
14	V _{EE} R	Module Receiver Ground	1
15	V _{CC} R	Module Receiver 3.3 V Supply	
16	V _{CC} T	Module Transmitter 3.3 V Supply	
17	V _{EE} T	Module Transmitter Ground	1
18	TD+	Transmitter Non-Inverted Data Input	
19	TD-	Transmitter Inverted Data Input	
20	V _{EE} T	Module Transmitter Ground	1

Note:

1. The module ground pins are isolated from the module case.
2. The pins shall be pulled up with 4.7K-10Kohms to a voltage between 3.14V and 3.46V on host board.
3. The pin is pulled up to VCCT with a 4.7K-10KΩ resistor in the module.

Digital Diagnostic Memory Map

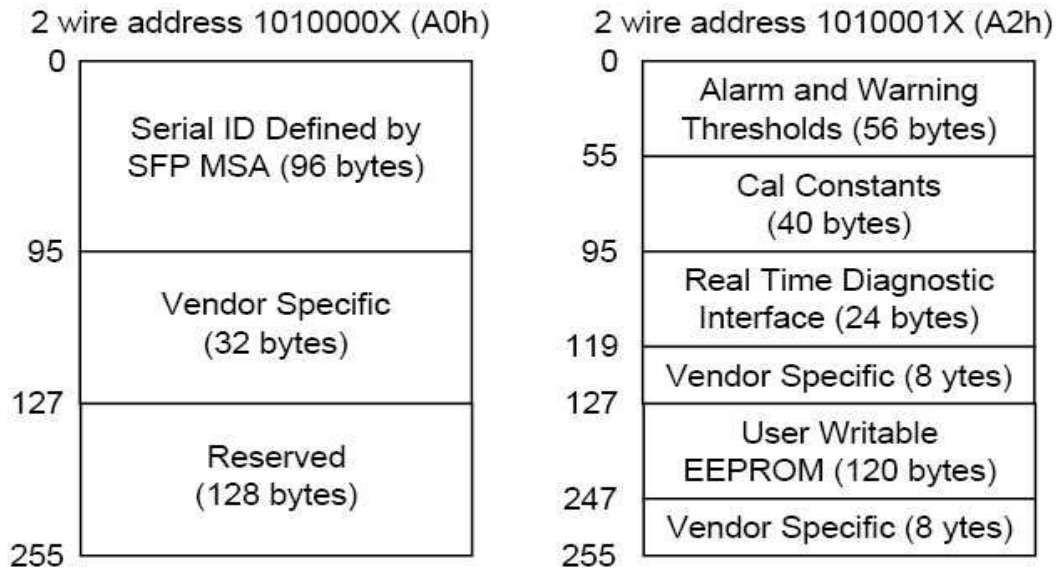

Figure 4, Memory Map

Mechanical

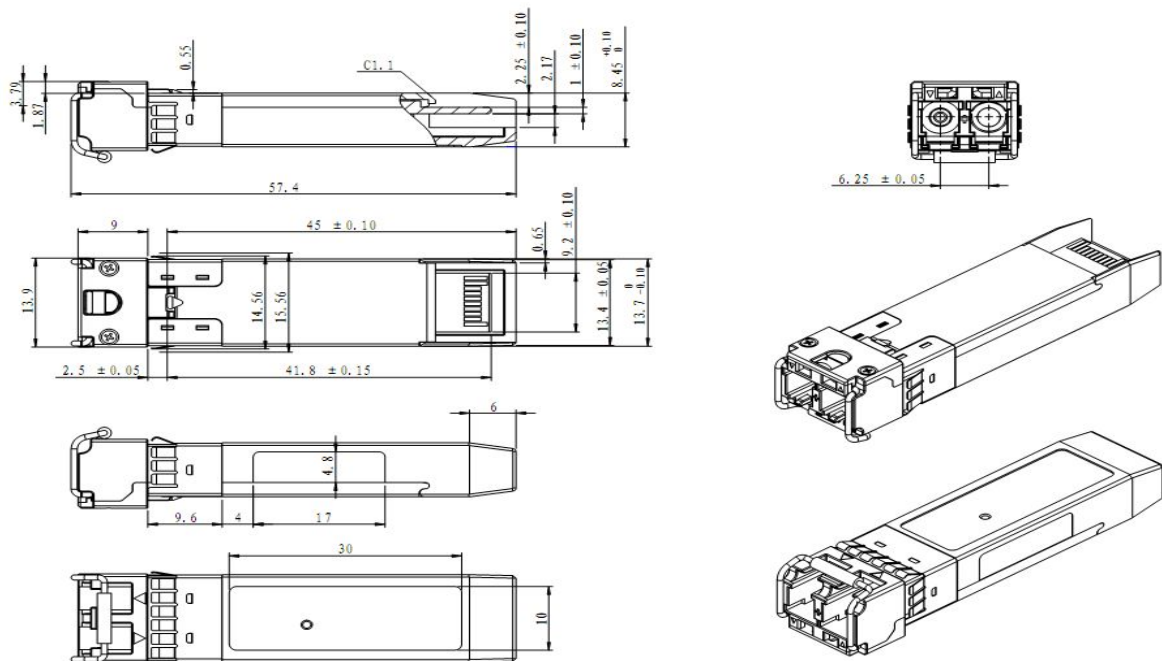

Figure 5, Mechanical Diagram

Order Information

Table 6-Order Information

Part No.	Bit Rate (Gbps)	Laser TX(nm)	Laser RX(nm)	Fiber Type	DDMI	Connector
SOSP-3199-02	10.3125	1310	1310	SMF	YES	LC

- Notice

SINOVO reserves the right to make changes to or discontinue any optical link product or service identified in this publication, without notice, in order to improve design and/or performance. Applications that are described herein for any of the optical link products are for illustrative purposes only. SINOVO makes no representation or warranty that such applications will be suitable for the specified use without further testing or modification.

- Contact

Shenzhen Sinovo Telecom Co.,Ltd
 Tel:+86(0)0755-32959919 Fax:+86(0)755 32959918
 Email: sales@sinovocorp.com
 Web:www.sinovocorp.com
 Factory ADD:5/F Chuang Park,Taoyuan Street Baoan District,Shenzhen,China
 Head Quarter:11/F, Taibang Technology Building,Gaoxin South 4th,Science and Technology Park South,Nanshan,Shenzhen,China 518040