



● Features :

- 125M 100BASE application
- 155M OC3 application/SDH/SONET
- 1310nm FP laser and PIN photodetector for 2KM,15KM and 40KM transmission
- 1550nm uncooled DFB laser and pin photodetector for 80KM
- SFP MSA package with duplex LC connector
- +3.3V single power supply
- Power consumption less than 1W
- Operating case temp
Standard temp: 0~+70°C
Industrial temp:-40~+85°C
- Compliant with RoHS

● Absolute Maximum Ratings

Table 1- Absolute Maximum Ratings

	Symbol	Min.	Typical	Max.	Unit	Notes
Supply Voltage	V _{CC3}	-0.5	-	+3.6	V	
Storage Temperature	T _s	-40	-	85	°C	
Operating Humidity	RH	+5	-	+95	%	

● Recommended Operating Conditions

Table 2- Recommended operating Conditions

Parameter		Symbol	Min.	Typical	Max.	Unit	Notes
Operating	Standard	T _c	0	-	+70	°C	
Case Temperature	Industrial		-40	-	+85	°C	
Power Supply Voltage		V _{CC}	3.13	3.3	3.47	V	
Power Supply Current		I _{CC}	-	-	300	mA	



Power Dissipation	Pd	-	-	1	W	
Data Rate		-	155	-	Mbps	

● Electrical Characteristics

Table 3- Electrical Characteristics

Parameter	Symbol	Unit	Min.	Typ.	Max.	Notes
Electrical Characteristics						
Supply Current	I _{CC}	mA	-	-	300	
Differential Data Input Swing		mV	200	-	2400	1
Differential Data Output Swing		mV	1450	1600-	1750	2
Differential Data input impedance		Ω	-	100	-	1
Signal Level(LVTTL H)		V	2.4	-	V _{CC}	
Signal Level(LVTTL L)		V	0	-	0.8	

Note:

1. Internally AC coupled, input termination may be required for CML or LVPECL applications.
2. Internally AC coupled, CML differential output stage.

● Optical Characteristics

Table 4-Optical Characteristics

SOCS-1303-02 (1310nm FP and PIN,2KM,NO DDMI)

SOCS-1303-02D (1310nm FP and PIN,2KM, DDMI)

Parameter	Symbol	Unit	Min.	Typ.	Max.	Notes
Optical transmitter Characteristics						
Data Rate		Mbps	-	155	-	
Center Wavelength Range	λ _C	nm	1290	1310	1330	
Spectral Width(@-20dB)	Δλ	nm	-	-	7.7	
Launch Optical Power	P ₀	dBm	-20	-	-14	1
Extinction Ratio	ER	dB	9	-	-	

SFP 100M&OC-3 Transceiver

SOSP-3101-02D

SOSP-3101-20D

SOSP-3101-40D

SOSP-5501-80D



Jitter Generation(pK-pK)		UI	-	-	0.1	
Jitter Generation(RMS)		UI	-	-	0.01	
Eye Diagram	Compliant with Telcordia GR-253-CORE and ITU-T G.957					
Optical receive Characteristics						
Data Rate		Mbps	-	155	-	
Receiver Sensitivity		dBm	-	-	-32	
Overload Input Optical Power	P_{IN}	dBm	-3	-	-	
Center Wavelength Range	λ_c	nm	1290	1310	1330	
LOS	LOS _A	dBm	-43	-	-	
	LOS _D		-	-	-33	
LOS Hysteresis		dB	0.5	-	-	

Note:

1. Coupled into 9/125 SMF.

Table 5-Optical Characteristics

SOCS-1303-15 (1310nm FP and PIN,15KM,NO DDMI)

SOCS-1303-15D (1310nm FP and PIN,15KM, DDMI)

Parameter	Symbol	Unit	Min.	Typ.	Max.	Notes
Optical transmitter Characteristics						
Data Rate		Mbps	-	155	-	
Center Wavelength Range	λ_c	nm	1290	1310	1330	
Spectral Width(@-20dB)	$\Delta\lambda$	nm	-	-	7.7	
Launch Optical Power	P_0	dBm	-15	-	-8	1
Extinction Ratio	ER	dB	9	-	-	
Jitter Generation(pK-pK)		UI	-	-	0.1	
Jitter Generation(RMS)		UI	-	-	0.01	
Eye Diagram	Compliant with Telcordia GR-253-CORE and ITU-T G.957					
Optical receive Characteristics						
Data Rate		Mbps	-	155	-	

SFP 100M&OC-3 Transceiver

SOSP-3101-02D

SOSP-3101-20D

SOSP-3101-40D

SOSP-5501-80D



Receiver Sensitivity		dBm	-	-	-32	
Overload Input Optical Power	P_{IN}	dBm	-8	-	-	
Center Wavelength Range	λ_C	nm	1290	1310	1330	
LOS	LOS_A	dBm	-43	-	-	
	LOS_D		-	-	-33	
LOS Hysteresis		dB	0.5	-	-	

Note:

1. Coupled into 9/125 SMF.

Table 6-Optical Characteristics

SOCS-1303-40 (1310nm FP and PIN,40KM,NO DDMI)

SOCS-1303-40D (1310nm FP and PIN,40KM, DDMI)

Parameter	Symbol	Unit	Min.	Typ.	Max.	Notes
Optical transmitter Characteristics						
Data Rate		Mbps	-	155	-	
Center Wavelength Range	λ_C	nm	1290	1310	1330	
Launch Optical Power	P_0	dBm	-5	-	0	1
Extinction Ratio	ER	dB	9	-	-	
Jitter Generation(pK-pK)		UI	-	-	0.1	
Jitter Generation(RMS)		UI	-	-	0.01	
Eye Diagram	Compliant with Telcordia GR-253-CORE and ITU-T G.957					
Optical receive Characteristics						
Data Rate		Mbps	-	155	-	
Receiver Sensitivity		dBm	-	-	-34	
Overload Input Optical Power	P_{IN}	dBm	-10	-	-	
Center Wavelength Range	λ_C	nm	1290	1310	1330	
LOS	LOS_A	dBm	-45	-	-	
	LOS_D		-	-	-35	
LOS Hysteresis		dB	0.5	-	-	

Note:



1: Coupled into 9/125 SMF.

Table 7-Optical Characteristics**SOCS-1503-80 (1550nm DFB and PIN,80KM,NO DDMI)****SOCS-1503-80D (1550nm DFB and PIN,80KM, DDMI)**

Parameter	Symbol	Unit	Min.	Typ.	Max.	Notes
Optical transmitter Characteristics						
Data Rate		Mbps	-	155	-	
Center Wavelength Range	λ_C	nm	1530	1550	1570	
Launch Optical Power	P_0	dBm	-5	-	0	1
Extinction Ratio	ER	dB	9	-	-	
Spectral Width(@-20dB)	$\Delta\lambda$	nm	-	-	1	
Jitter Generation(pK-pK)		UI	-	-	0.1	
Jitter Generation(RMS)		UI	-	-	0.01	
Eye Diagram	Compliant with Telcordia GR-253-CORE and ITU-T G.957					
Optical receive Characteristics						
Data Rate		Mbps	-	155	-	
Receiver Sensitivity		dBm	-	-	-34	
Overload Input Optical Power	P_{IN}	dBm	-10	-	-	
Center Wavelength Range	λ_C	nm	1530	1550	1570	
LOS	LOS_A	dBm	-45	-	-	
	LOS_D		-	-	-35	
LOS Hysteresis		dB	0.5	-	-	

Note:

1. Coupled into 9/125 SMF.



● Recommended Interface Circuit

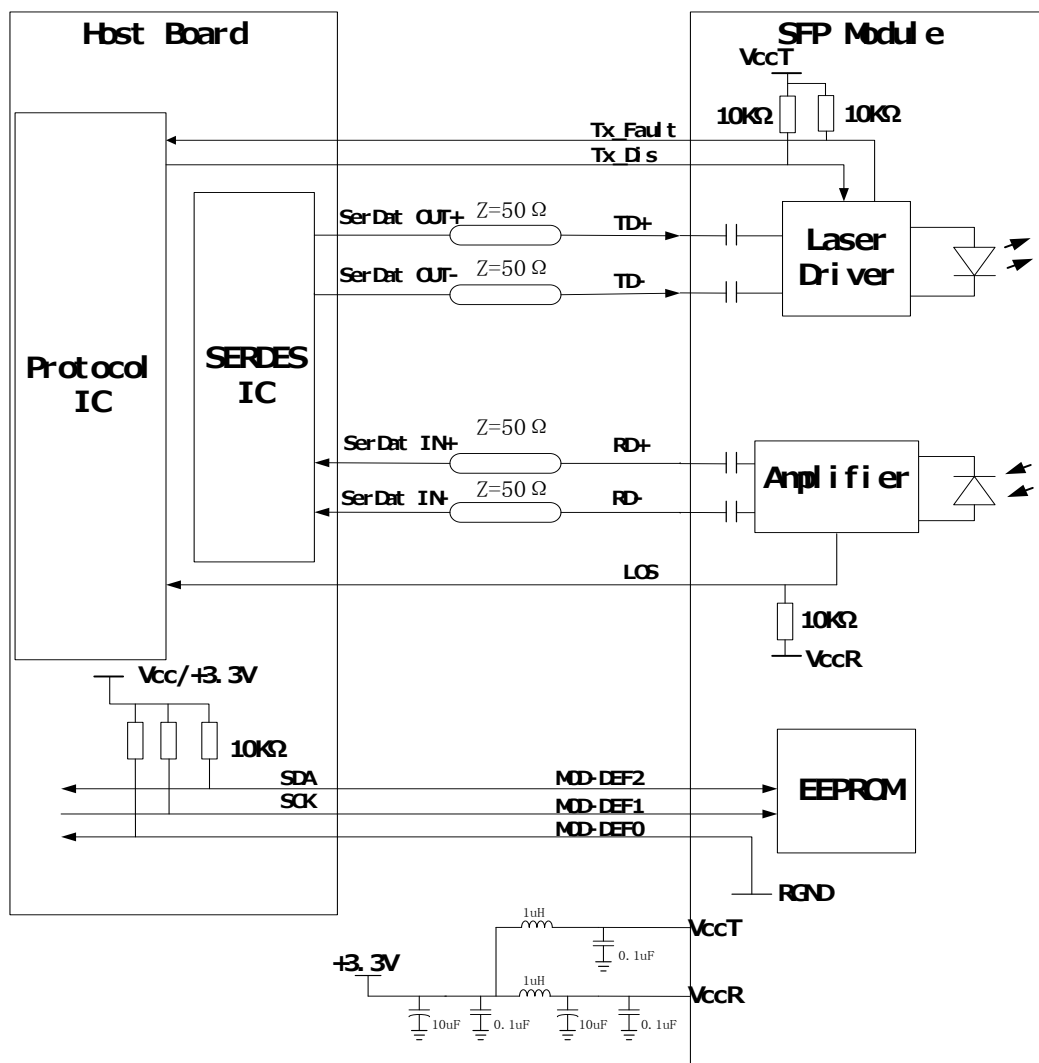

Figure 1, Recommended Interface Circuit



● Recommended Host Board Power Supply Circuit

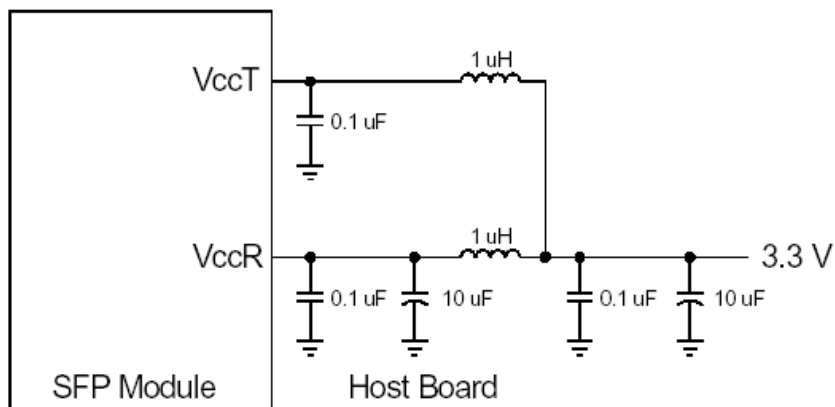

Figure 2, Recommended Host Board Power Supply Circuit

● Pin arrangement

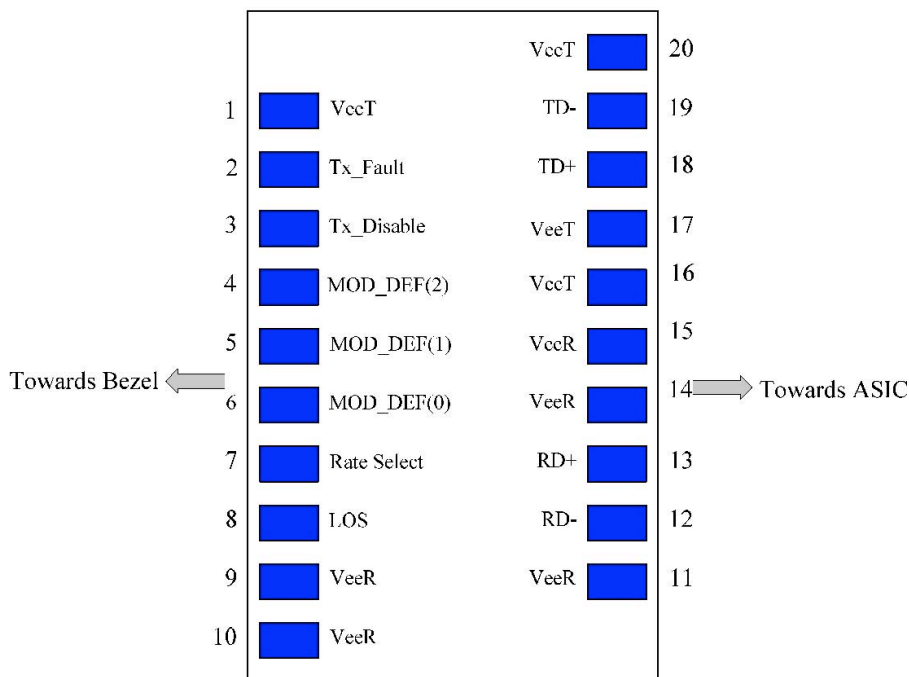

Figure 3, Pin View

SFP 100M&OC-3 Transceiver

SOSP-3101-02D

SOSP-3101-20D

SOSP-3101-40D

SOSP-5501-80D



Table 8-Pin Function Definitions

Pin	Name	FUNCTION	Plug Seq.	Notes
1	VeeT	Transmitter Ground	1	
2	TX Fault	Transmitter Fault Indication	3	Note 1
3	TX Disable	Transmitter Disable	3	Note 2, Module disables on high or open
4	MOD-DEF2	Module Definition 2	3	Note 3, Data line for Serial ID.
5	MOD-DEF1	Module Definition 1	3	Note 3, Clock line for Serial ID.
6	MOD-DEF0	Module Definition 0	3	Note 3, Grounded within the module.
7	Rate Select	Not Connect	3	Function not available
8	LOS	Loss of Signal	3	Note 4
9	VeeR	Receiver Ground	1	Note 5
10	VeeR	Receiver Ground	1	Note 5
11	VeeR	Receiver Ground	1	Note 5
12	RD-	Inv. Received Data Out	3	Note 6
13	RD+	Received Data Out	3	
14	VeeR	Receiver Ground	1	Note 5
15	VccR	Receiver Power	2	3.3 ± 5%
16	VccT	Transmitter Power	2	3.3 ± 5%
17	VeeT	Transmitter Ground	1	Note 5
18	TD+	Transmit Data In	3	
19	TD-	Inv. Transmit Data In	3	
20	VeeT	Transmitter Ground	1	Note 5

Note:

- TX Fault is open collector output which should be pulled up externally with a 4.7K ~10KΩ resistor on the host board to voltage between 2.0V and V_{CC}+0.3V. Logic 0 indicates normal operation; logic 1 indicates a laser fault of some kind. In the low state, the output will be pulled to less than 0.8V.
- TX Disable input is used to shut down the laser output per the state table below. It is pulled up within the module with a 4.7~ 10K resistor.

Low (0- 0.8V):	Transmitter on
Between (0.8V and 2V):	Undefined
High (2.0 – V _{CC} T):	Transmitter Disabled
- MOD-DEF 0, 1, 2. These are the module definition pins. They should be pulled up with a 4.7~10K resistor on the host board to supply less than V_{CC}T+0.3V or V_{CC}R+0.3V.
 MOD-DEF 0 is grounded by the module to indicate that the module is present.
 MOD-DEF 1 is clock line of two wire serial interface for optional serial ID.
 MOD-DEF 2 is data line of two wire serial interface for optional serial ID.
- LOS (Loss of signal) is an open collector output, which should be pulled up with a 4.7k~10kΩ resistor on the host board to a voltage between 2.0V and V_{CC}+0.3V. Logic 0 indicates normal



operation; logic 1 indicates loss of signal. In the low state, the output will be pulled to less than 0.8V.

5. These are the differential receiver outputs. They are AC-coupled 100Ω differential lines which should be terminated with 100Ω differential at the user SERDES. The AC coupling is done inside the module and thus not required on the host board.
6. These are the differential transmitter inputs. They are AC-coupled, differential lines with 100Ω differential termination inside the module.

● Digital Diagnostic Memory Map

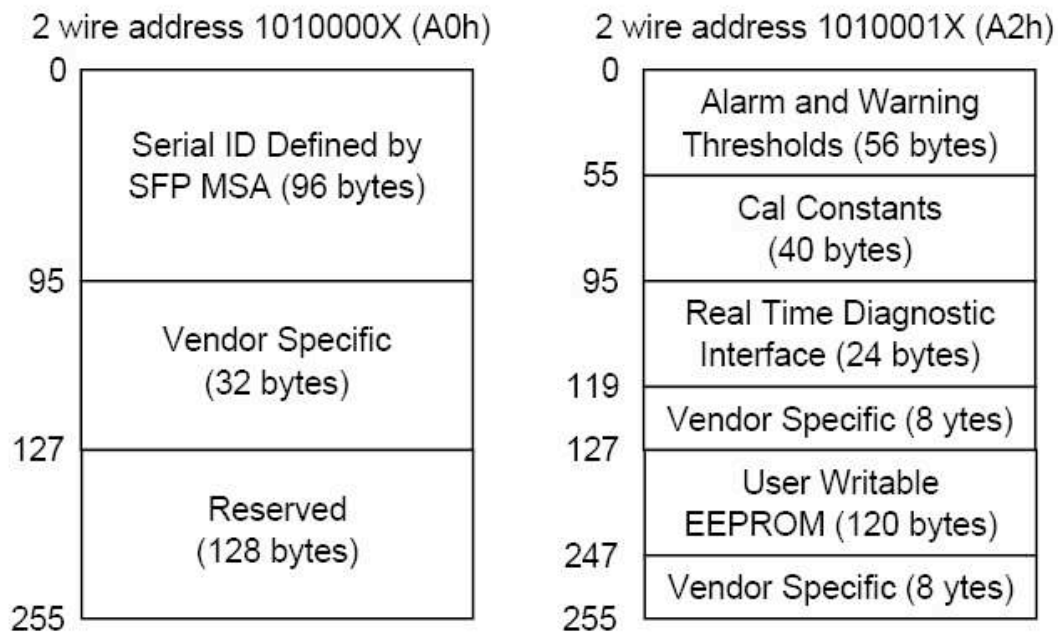

Figure 4, memory map



● Mechanical Diagram

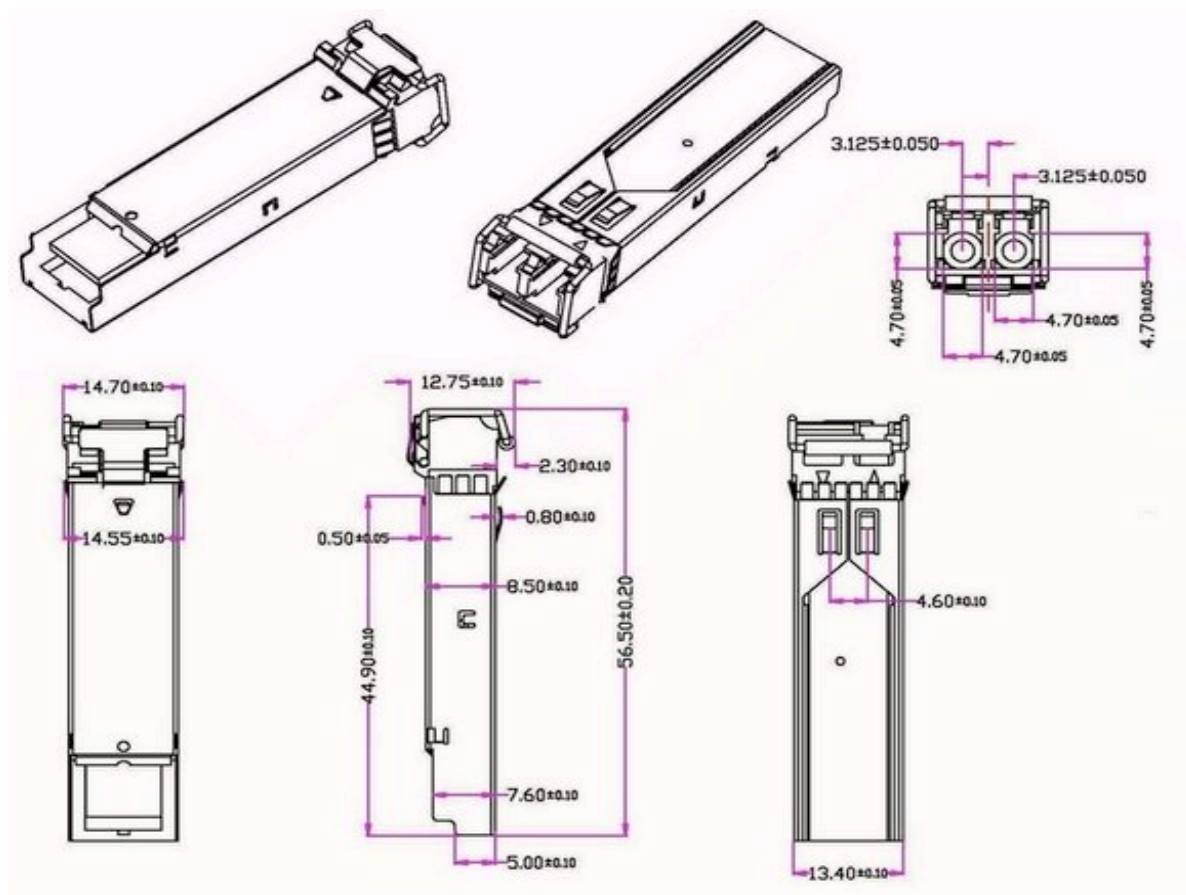

Figure 5, mechanical diagram

● Order Information

Table 9-order information

Part Number	Product Description
SOSP-3101-02	SFP 1310nm,155M, 2KM, NO DDM ,0°C~70°C
SOSP-3101-02I	SFP 1310nm, 155M, 2KM, NO DDM , -40°C~85°C
SOSP-3101-02D	SFP 1310nm, 155M, 2KM, DDM ,0°C~70°C
SOSP-3101-02DI	SFP 1310nm, 155M, 2KM, DDM , -40°C~85°C
SOSP-3101-20	SFP 1310nm, 155M, 20KM, NO DDM ,0°C~70°C

SFP 100M&OC-3 Transceiver

SOSP-3101-02D

SOSP-3101-20D

SOSP-3101-40D

SOSP-5501-80D



SOSP-3101-20I	SFP 1310nm, 155M, 20KM, NO DDM , -40°C ~ 85°C
SOSP-3101-20D	SFP 1310nm, 155M, 20KM, DDM , 0°C ~ 70°C
SOSP-3101-20DI	SFP 1310nm, 155M, 20KM, DDM , -40°C ~ 85°C
SOSP-3101-40	SFP 1310nm, 155M, 40KM, NO DDM , 0°C ~ 70°C
SOSP-3101-40I	SFP 1310nm, 155M, 40KM, NO DDM , -40°C ~ 85°C
SOSP-3101-40D	SFP 1310nm, 155M, 40KM, DDM , 0°C ~ 70°C
SOSP-3101-40DI	SFP 1310nm, 155M, 40KM, DDM , -40°C ~ 85°C
SOSP-5501-80	SFP 1550nm, 155M, 80KM, NO DDM , 0°C ~ 70°C
SOSP-5501-80I	SFP 1550nm, 155M, 80KM, NO DDM , -40°C ~ 85°C
SOSP-5501-80DI	SFP 1550nm, 155M, 80KM, DDM , 0°C ~ 70°C
SOSP-5501-80DI	SFP 1550nm, 155M, 80KM, DDM , -40°C ~ 85°C

● Notice

SINOVO reserves the right to make changes to or discontinue any optical link product or service identified in this publication, without notice, in order to improve design and/or performance. Applications that are described herein for any of the optical link products are for illustrative purposes only. SINOVO makes no representation or warranty that such applications will be suitable for the specified use without further testing or modification.

● Contact

Shenzhen Sinovo Telecom Co.,Ltd
Tel:+86(0)755-32959919 Fax:+86(0)755 32959918
Email: sales@sinovocorp.com
Web:www.sinovocorp.com